

# PRODUCT SPECIFICATION

**EG8200Mini** Standard Ver. | Rail Ver.

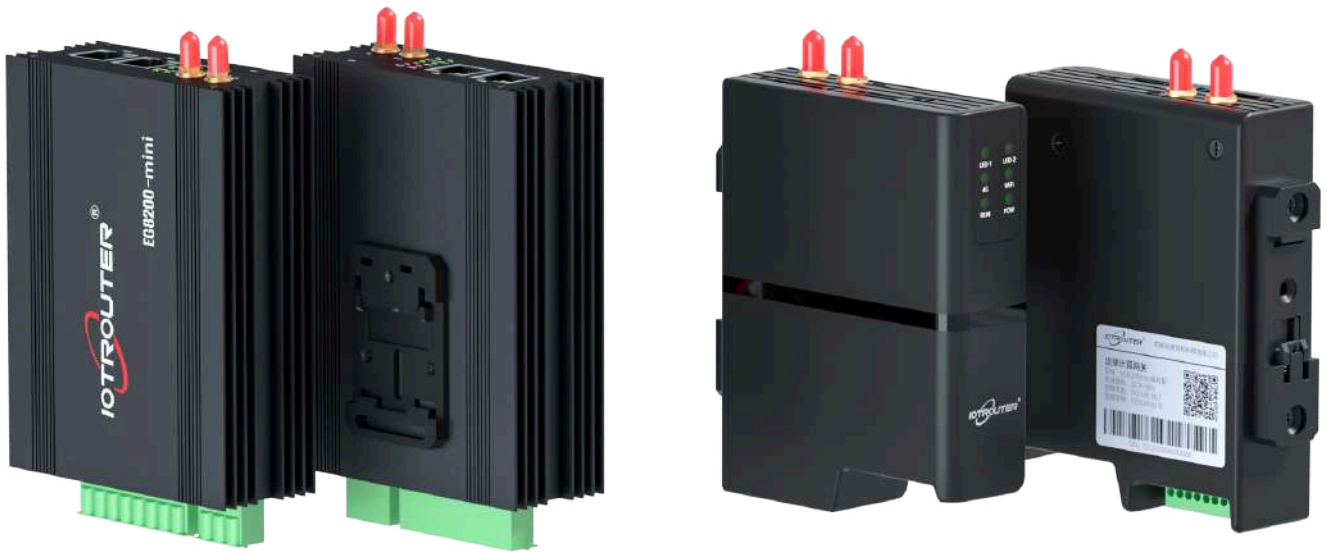

Chengdu Zongheng Intelligence  
Control Technology Co., Ltd.

## PRODUCT INTRODUCTION

## 产品介绍 ▶▶▶



EG series products are edge computing gateways launched by IOTRouter Chengdu. With its **rich hardware interfaces, drag-and-drop programming method, Zero Code design concept, convenient remote management** and other characteristics, It can **quickly, flexibly, accurately** and **efficiently** respond to various IoT industry needs.

EG series products abstract complex hardware interfaces, different industrial network protocols, etc. into Nodes one by one. Users can **use these Nodes flexibly to replace the traditional complex and inefficient coding process** by dragging and connecting. Really let customers focus on business logic and quickly create their own gateway equipment. The mission of EG series products is to continuously develop new Nodes to serve industry customers to **adapt to the fragmentation of IoT industry needs**.

## PRODUCT SPECIFICATION

## 产品规格 ▶▶▶

Model		EG8200Mini (Standard Ver. / Rail Ver.)
Core Configuration	CPU	2 Cores A7@1.2G
	Memory	512M
	eMMC	4G
Storage	SD card	128G <sup>max</sup> (Optional)
4G	Module	Quectel-CAT1 (4G)
	Frequency Band	LTE-FDD: B1/B3/B5/B8 LTE-TDD: B34/B38/B39/B40/B41
	Transmit Power	LTE-FDD: Class 3 (23 dBm ±2 dB) LTE-TDD: Class 3 (23 dBm ±2 dB)
	Bandwidth (The maximum rate is theoretical, and the actual rate refers to the network configuration.)	LTE-FDD: Max 10Mbps(DL)/Max 5Mbps(UL) LTE-TDD: Max 8.96Mbps(DL)/Max 3.1Mbps(UL)
WiFi	Wireless Standards	IEEE 802.11b/g/n
	Wireless Frequency	2.4~2.4835GHz
	WiFi Mode	AP+Station
	Theoretical Rate	150Mbps
	Optimal Communication Distance	10m
	Number of AP Mode Links	20
Ethernet	WAN	1 * 10M/100M/1000M Self-Adaptive
	LAN	1 * 10M/100M Self-Adaptive
RS232	Number of Interfaces	1 Way
	Terminals	RX、TX、GND
	Baud Rate	2400~921600bps
	Data Bits	7、8
	Stop Bits	1、2
	Check Digit	NONE (No Check Digit) EVEN (Even Check) ODD (Odd Check)
	Protection	Anti-static, Anti-surge
RS485	Number of Interfaces	2-way
	Terminals	A、B
	Baud Rate	2400~921600bps
	Data Bits	7、8
	Stop Bits	1、2
	Check Digit	NONE (No Check Digit) EVEN (Even Check) ODD (Odd Check)
	Protection	Anti-static, Anti-surge

## PRODUCT SPECIFICATION

## 产品规格 ▶▶▶

RTC	Local Clock	√
Electrical Parameters	Authentication	CE
	Adapter	12V/2A
	Operating Voltage	9~36V
	Operating Current	150mA/12V
Environmental Parameters	Operating Temperature	-40~85°C
	Storage Temperature	-40~85°C
	Operating Humidity	0~95%RH (No Condensation)
	Store Humidity	0~95%RH (No Condensation)
Mechanical Parameters	Size	115*90*35mm / 125*95*32mm
	Housing Material	Aluminium Profiles PC/ABS (AC2300)
	Installation	Guide Rail
	Heat Dissipation	Passive Cooling
	REST Button	Press and Hold for 10s to Reset
EMC	Electrostatic Discharge	Air Discharge level3 ±8KV Contact Discharge level2 ±4KV
	Surge	level2 ±1KV
	Burst (EFT)	level2 ±1KV
Software Features	Remote O&M	√
	Remote Management	√
	Remote Upgrades	√
	Virtual Network Port	√
	Virtual serial port	√
	Time Series Databases	√
	Visual Programming	√
	PLC Protocols	Hundreds of PLC Models
	Industry Protocols	CJ188 / DLT645 / HJ212 / IEC104 / Modbus / OPC UA / BACnet
	Network Protocols	MQTT / HTTP / TCP / UDP / WEB SOCKET / Alibaba Cloud IoT Platform / OneNET
System	System	Linux
	Version	Ubuntu 20.04.5 Custom Edition

## THE APPENDIX

## 附录 ▶▶▶

## EG8200 Series Edge Computing Gateway PLC Protocols

The gateway is categorized according to the hierarchical structure of **brand->protocol->model**, and representative PLC models are selected for testing in each category. The rest of the supported models are from the official documents.

Note: The gateway supports the standard MODBUS RTU/TCP protocol, which is supported by all mainstream PLCs. (For example, HollySys, Haiwell, Yokogawa, Runpower, etc.)

Brand	Protocol	Interface	PLC Model
SIEMENS (西门子)	<b>Tips:</b>		<b>Siemens in the sale of the series all support S7 protocol communication, it is recommended to use the S7 protocol communication.</b>
	S7	Ethernet	S7-S200smart、S7-S200 Series、S7-S300 Series、S7-S400 Series、S7-S1200 Series、S7-S1500 Series
	PPI	Serial port	S7-200 Series
MELSEC (三菱)	<b>Tips:</b>		<b>Mitsubishi mainly uses MC protocol for communication, FX5 Series, FX3 Series, Q Series, etc. are tested.</b>
	EtherNet/IP	Ethernet	FX5-ENET/IP Series、RJ71EIP91 Series、QJ71EIP71 Series
	MC-1E/MC-3E	Ethernet	FX5 Series、RJ71EN71 Series、RnENCPU Series、LJ71E71 Series、QJ71E71 Series、QnUCPU Series、FX3 Series
	MODBUS TCP	Ethernet	FX5 Series、RJ71EN71 Series、RnENCPU Series、LJ71E71 Series、QJ71E71 Series
	MC-3C	Serial port	FX5 Series、RJ71C24 Series、LJ71C24 Series、QJ71C24 Series
	MODBUS RTU	Serial port	FX5 Series、RJ71C24 Series、LJ71C24 Series、QJ71C24 Series、FX3 Series
	FxLinks	Serial port	FX3 Series、FX2 Series、FX1 Series、FX0 Series
OMRON (欧姆龙)	<b>Tips:</b>		<b>Omron mainly uses the Fins protocol for communication.</b>
	EtherNet/IP	Ethernet	NX7 Series、NX1 Series、NX1P Series、NJ Series、CJ1W-EIP21
	Fins	Ethernet	CP Series、CS Series、CJ Series、CV Series
HostLink	Serial port	CP Series、CS Series、CJ Series、CV Series、C Series	
LSis (LS 电气)	<b>Tips:</b>		<b>LS mainly uses FEnet/Cnet protocol for communication.</b>
	XGB FEnet	Ethernet	XGB Series (XBC/XEC U、XBL-EMTA)
	XGK FEnet	Ethernet	XGT Series (XGL-EFMT、XGL-EFMF、XGL-EH5T)
	XGB Cnet	Serial port	XGB Series (XBC/XEC U、XBL-C21A、XBL-C41A)
XGK Cnet	Serial port	XGT Series (XGL-CH2A、XGL-C21A、XGL-C41A)	

## THE APPENDIX

## 附录 ▶▶▶

Brand	Protocol	Interface	PLC Model
AllenBrandly (罗克韦尔)	<b>Tips:</b>		<b>Rockwell mainly uses CIP, DF1 protocol for communication.</b>
	EtherNet/IP	Ethernet	ControlLogix Series、CompactLogix Series、Micro800 Series (820、850、870)
	DF1	Serial port	ControlLogix Series、CompactLogix Series (5069-SERIAL module)、Micro800 Series (820、830、850、870) SLC Series (500、5/03、5/04、5/05)、Micro-Logix Series (1000、1100、1200、1500)
Beckhoff (倍福)	<b>Tips:</b>		<b>Beckhoff mainly uses the ADS protocol for communication.</b>
	ADS	Ethernet	CX Series、TwinCAT2、TwinCAT3
Inovance (汇川)	<b>Tips:</b>		<b>Inovance mainly adopts MODBUS protocol for communication.</b>
	MODBUS TCP	Ethernet	AC Series、AM Series、H5U Series、H3U Series
	MODBUS RTU	Serial port	AC Series、AM Series、H5U Series、H3U Series、H1U Series
Keyence (基恩士)	<b>Tips:</b>		<b>Keyence mainly uses the KV protocol for communication.</b>
	MC-3E	Ethernet	KV-8000 Series、KV-7000 Series、KV-5500 Series、KV-5000 Series、KV-EP21V、KV-LE21V、KV-LE20V、KV-LE20A and other Ethernet units
	KV	Serial port	KV-7300、KV-3000、KV-1000、KV-700、KV Nano、KV-L21V、KV-L20V
Panasonic (松下)	<b>Tips:</b>		<b>Panasonic mainly uses the Mewtocol protocol for communication.</b>
	MC-3E	Ethernet	FP7 Series、FP0H Series、FP-XH Series
	Mewtocol	Ethernet	FP7 Series、FP0H Series、FP-XH Series
	Mewtocol	Serial port	FP7 Series、FP0H Series、FP-XH Series、FP-X0 Series、FP0R Series
Delta (台达)	<b>Tips:</b>		<b>Delta mainly uses MODBUS protocol for communication.</b>
	MODBUS TCP	Ethernet	AH Series、AS Series、AX-3 Series、DVP Series (built-in Ethernet)
	MODBUS RTU	Serial port	AH Series、AS Series、AX-3 Series、DVP Series
XinJE (信捷)	<b>Tips:</b>		<b>XinJE mainly uses MODBUS protocol for communication.</b>
	MODBUS TCP	Ethernet	CCSD Series、XA Series、XS Series、XG Series、XL Series
	MODBUS RTU	Serial port	CCSD Series、XA Series、XS Series、XG Series、XL Series、XC Series、XD Series
MegMeet (麦格米特)	<b>Tips:</b>		<b>MegMeet mainly uses MODBUS protocol for communication.</b>
	MODBUS TCP	Ethernet	MC5100 Series、MC280 Series、MC200 Series、MC100 Series、MC80 Series
	MODBUS RTU	Serial port	MC5100 Series、MC280 Series、MC200 Series、MC100 Series、MC80 Series
Yaskawa (安川)	<b>Tips:</b>		<b>Yaskawa mainly uses the MEMOBUS protocol for communication (supports S7).</b>
	Memobus	Ethernet	GL120/130 Series、GL60 Series、MP3000 Series、MP2300 Series、Z1000 Series
Fatek (永宏)	<b>Tips:</b>		<b>Fatek mainly uses the Fatek protocol for communication.</b>
	Fatek	Serial port	FBs Series
Vigor (丰炜)	<b>Tips:</b>		<b>Vigor mainly uses the VS private protocol for communication.</b>
	VS	Serial port	VS Series
Fuji (富士)	<b>Tips:</b>		<b>Fuji mainly uses the SPH/SPB protocol for communications.</b>
	SPH	Ethernet	SPH Series
	SPB	Serial port	SPB Series

WIRING INSTRUCTION

接线说明 ▶▶▶

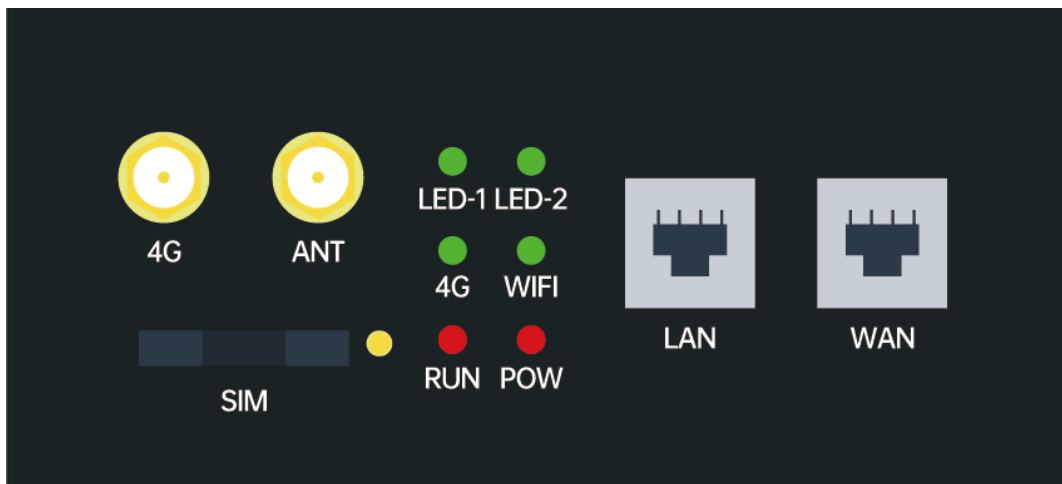

EG8200Mini Standard Ver. Interface Identification-1

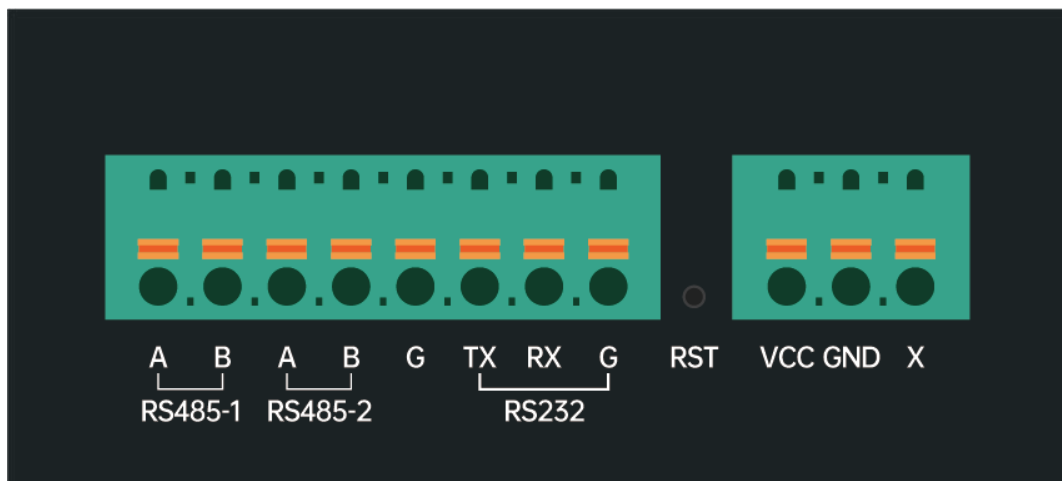

EG8200Mini I Standard Ver. nterface Identification-2

## WIRING INSTRUCTION

## 接线说明 ▶▶▶

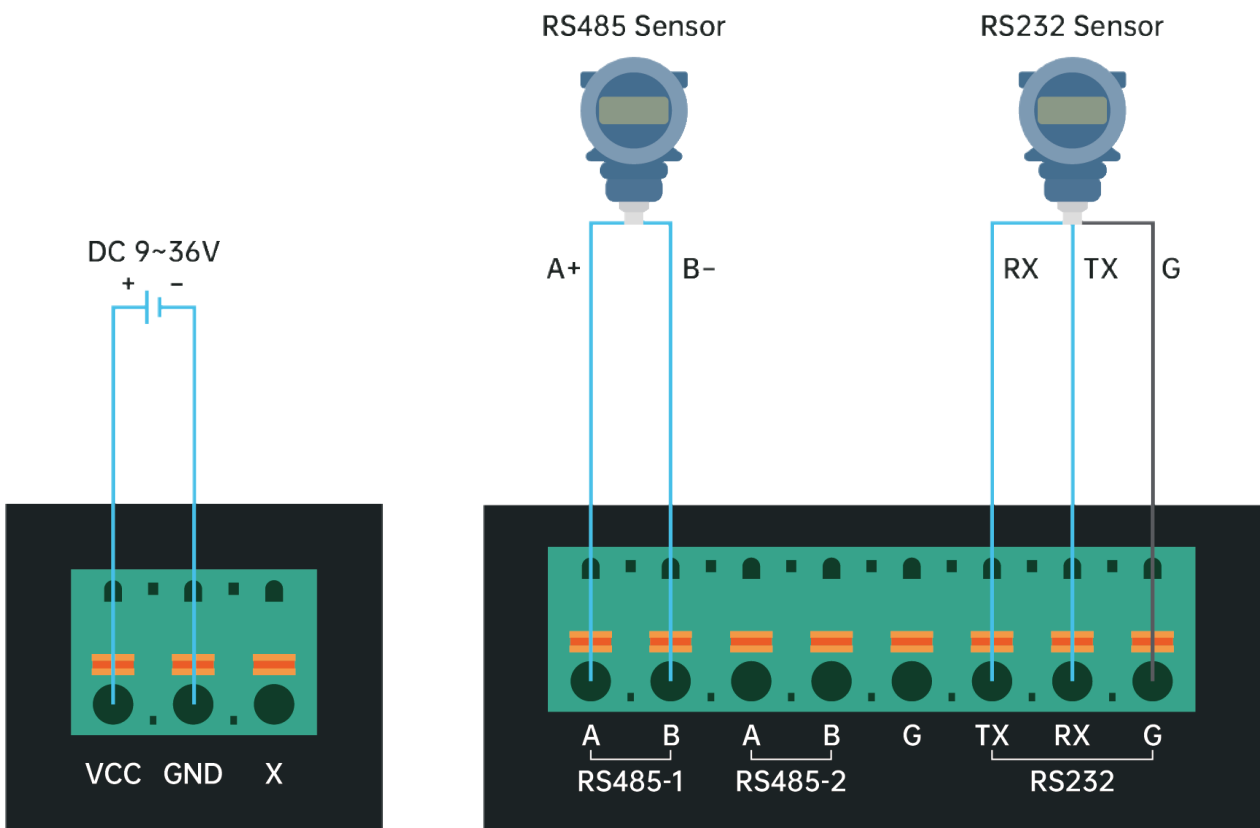

Standard Ver.  
Power Wiring Diagram

Standard Ver.  
RS485/RS232 Wiring Diagram



WIRING INSTRUCTION

接线说明 ▶▶▶



EG8200Mini Rail Ver. Interface Identification-1



EG8200Mini Rail Ver. Interface Identification-1

WIRING INSTRUCTION

接线说明 ▶▶▶

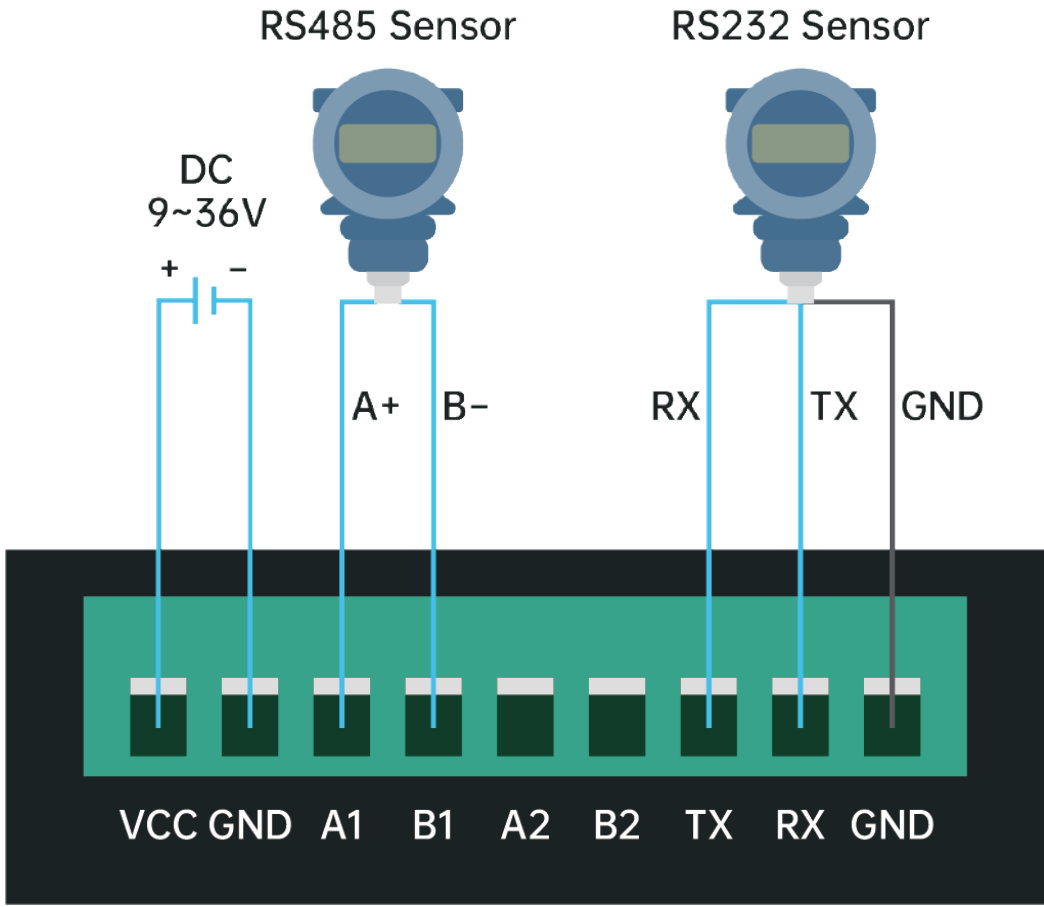

Rail Ver.

Power & Serial port Wiring Diagram



INSTALLATION INSTRUCTION

安装说明 ▶▶▶

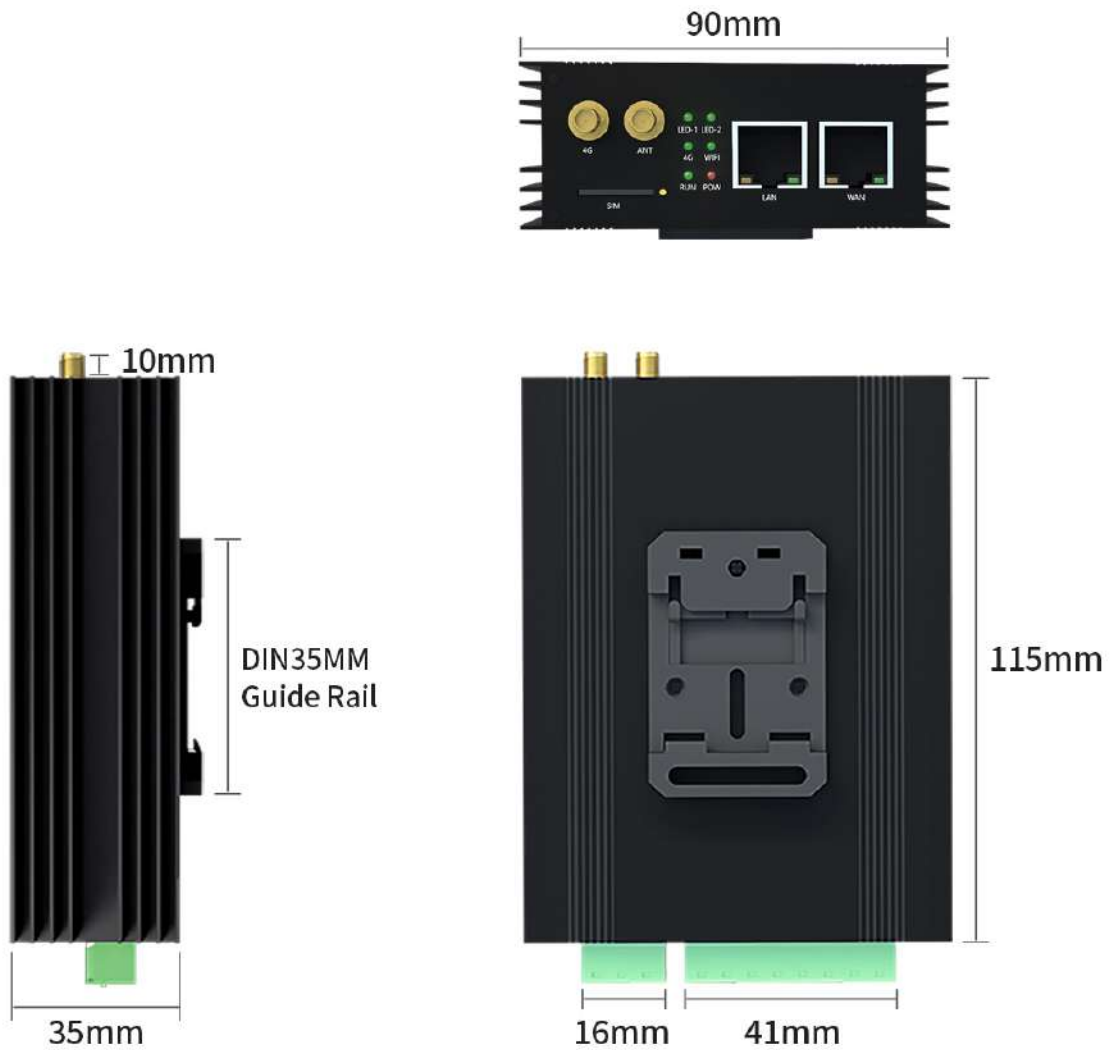

Standard Ver.  
Product Size

INSTALLATION INSTRUCTION

安装说明 ▶▶▶

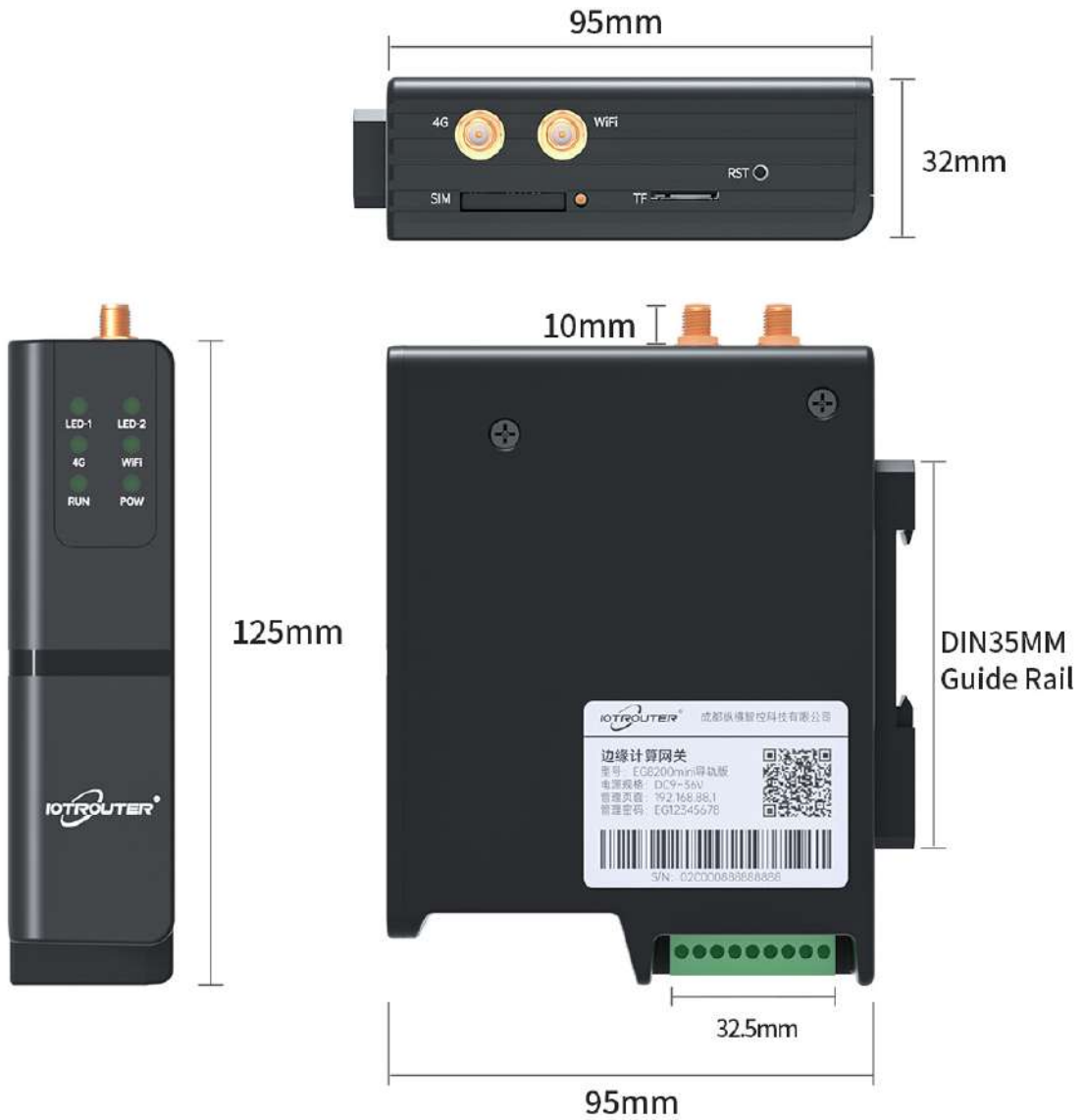

Rail Ver.  
Product Size

# A LEADING PROVIDER OF INTEGRATED IT AND OT PRODUCTS

R&D Center :  
CHENGDU IOTRouter TECHNOLOGY CO., LTD  
No. 599, Section 1, Huafu Avenue, Shuangliu  
District, Chengdu city, Sichuan Province, China

Website :  
[www.iotrouter.com](http://www.iotrouter.com)

Mail :  
[agnes@iotrouter.com](mailto:agnes@iotrouter.com)



WhatsApp